

Colt ventilation systems for car parks and service areas



# Introduction

Front Cover: Golden Square Shopping Centre, Warrington

## VENTILATION SYSTEMS FOR CAR PARKS AND SERVICE AREAS

Ventilation systems for car parks and service areas are required to achieve two objectives.

Firstly, when the car park or service area is in general use, it is important that the exhaust gases produced by vehicles are effectively removed and that there are no pockets of stagnant air.

Secondly, in the event of a fire, assistance needs to be given to the Fire Service to clear smoke from the car park during and after the fire.

Such ventilation systems may in addition be designed to provide clear smoke free access for fire fighters to tackle the seat of the fire, or alternatively to protect means of escape from the car park. These more complex systems are in excess of Building Regulations requirements and are used as compensating features when other requirements are not met.

This leaflet is intended to provide an understanding of the legislative framework and how car park ventilation systems can help meet legislative requirements and achieve the design objectives.

## LEGISLATION AND STANDARDS

The ventilation requirements for car parks are detailed in:

- Approved Document B to the Building Regulations (England and Wales); Scottish Buildings Standards Technical Handbooks (Scotland); Technical Booklet E (Northern Ireland).
- Approved Document F - Ventilation
- BS 7346-7: 2006 - "Components for Smoke and Heat Control Systems. Code of practice on functional recommendations and calculation methods for smoke and heat control systems for covered car parks"
- BS 9999:2008 - Code of practice for fire safety in the design, management and use of buildings
- CFD Modelling for Car Park Ventilation Systems – a guide for designers and regulators (FETA, 2007)
- APEA Code of Practice
- BR 368
- SCA Guide "Design of Smoke Ventilation Systems for Loading Bays and Coach Parks - a guide for system designers"

These documents give design guidance on ventilation of car parks and service areas, including both Building Regulations compliant systems and fire engineered systems.

The Approved Documents describe three traditional methods of ventilation for car parks, as follows.

### 1. Open Sided Car Parks

These are completely above ground level with permanent wall openings on each level, equal to 5% of the plan area, arranged to provide cross ventilation. These openings are considered to provide sufficient ventilation for clearance of both smoke and vehicle exhaust fumes.

### 2. Naturally Ventilated Car Parks

These have permanent wall openings on each level, equal to 2.5% of the plan area, arranged to provide cross flow ventilation. This is sufficient ventilation for smoke clearance, but in addition mechanical extract providing three air changes per hour is needed to remove exhaust fumes.

Note: The 5% and 2.5% areas are defined in Approved Document F as "equivalent areas". For openings that are obstructed in any way, by louvres, screens, etc, the aerodynamic coefficient of the obstruction is required for the calculation of the equivalent area.



*East Side Plaza, Gunwharf Quays, Portsmouth  
8 Cyclone induction fans and 3 Jetstream impulse fans  
move the air from the entrance ramp towards the  
extract system, which was also supplied by Colt.*

### 3. Mechanically Ventilated Car Parks

Where natural ventilation is not possible, such as where the car park is in a basement or fully enclosed, a mechanical extract system should be used. For mechanically ventilated car parks, the basic requirements are that there should be a mechanical ventilation system that will provide 6 air changes per hour (ACH) for general ventilation on all levels and 10 ACH on the fire floor in the event of a fire. The system should be capable of operating at temperatures of up to 300°C for 60 minutes and ductwork and fixings should be made from materials that have a melting point above 800°C. The system should have at least 2 extract fans, each providing 50% of the extract, with a secondary power supply to operate in the event of a mains power failure. Extract points should be designed with 50% of the outlets at high level and 50% at low level.

Colt Car Park Ventilation Systems can be designed to meet the requirements of other international standards such as the NFPA and Australia/New Zealand standards, and Colt has installations of Car Park Ventilation Systems in many countries around the world.

We would be pleased to assist you in the development of designs for your car park wherever it may be.

### MECHANICALLY VENTILATED CAR PARKS

There are a number of issues relating to ducted mechanical extract systems which often cause problems for designers:

- The ductwork runs underneath the ceiling, reducing the already restricted height normally available.
- Downstand beams require the ducting to be set down below them, thus diminishing the height even further.
- Low level extract points are required, often needing protective barriers to surround them, and these take up valuable floor space.
- The ductwork gives the car park a cluttered look and can interfere with CCTV coverage and lighting.

# The Design Approaches

## THE DESIGN APPROACHES

There are 2 approaches described in BS7346-7.

### **Smoke Clearance**

Such systems are not intended to assist means of escape in case of fire, but to assist fire fighters by providing smoke clearance. Even a casual inspection of the requirements shows that these methods cannot be expected to do more than limit smoke density and speed smoke clearance once the fire is extinguished.

Where impulse fans are used, they are located over the roadways in a layout engineered to ensure there are no areas where it would be possible for fumes to build up due to lack of air movement. In most car parks only a single large extract point is required, located as far as possible from the main air inlet openings. This method satisfies the requirements of both Approved Documents.

These systems are suitable for use in sprinkler protected car parks. Close co-ordination is needed to maximise the benefits of both sprinklers and ventilation.

### **Smoke Control**

The alternative approach is to control smoke movement in order to offset other fire provisions, such as escape distances, sprinklers, compartmentation or to provide clear access for fire fighters to tackle the source of the fire. The system requires an addressable fire detection system so that the site of the fire can be pinpointed. A control system then starts the selected impulse and extract fans to control the direction of the smoke and provide clear air upstream of the fire. This will allow fire fighters to access the car park behind the fire and bring it under control.

By virtue of the improved fire-fighter access it may be possible to delete sprinklers from car parks where they would otherwise be needed.

This method can also be used to protect means of escape in large car parks with excess travel distances. However it is generally a more expensive option, requiring more complex controls and additional extract.

### **CFD**

Design of impulse systems is usually proven by use of CFD (Computational Fluid Dynamic) analysis.

This allows detailed computation of airflow in car parks, taking into account the often complex geometry of individual buildings. This is often essential to demonstrate to the local authority that designs will perform satisfactorily, by showing that sufficient air movement is provided throughout the car park and, for smoke control systems, the extent of the smoke spread.

CFD modelling has the objective of confirming the viability of the ventilation scheme. Colt offers CFD modelling of the system and a full technical report for local authority approval prior to installation. Just to be sure that its CFD modelling approach was reliable, Colt undertook a series of empirical full scale hot smoke tests. See next section.

Since CFD is a key component of car park ventilation design, and there has been inadequate guidance on this element, members of the Smoke Control Association have produced A Guide to CFD in Car Parks to complement BS 7346-7. The guidance makes it easier for designers to validate their designs and for building control bodies to sanction them. This guide is available from the Federation of Environmental Trade Associations.

The Observatory Apartments, Walsall

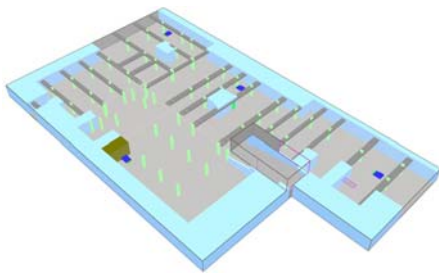

A 3D isometric view of the car park.

Red on the scale represents air speeds of 3m/s and above, dark blue represents 0m/s.

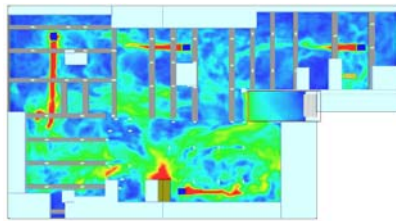

A high level slice showing air speed contours just below the cyclone fans.

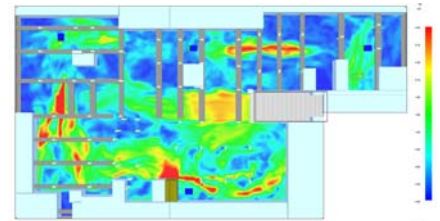

A low level slice showing air speed contours just above floor level.

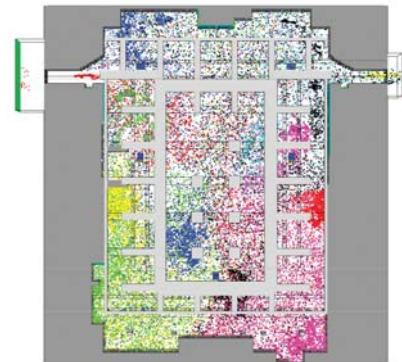
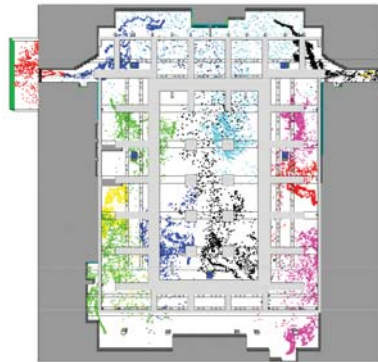
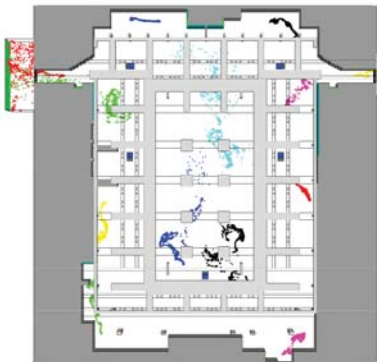

The CFD images are part of an animation sequence. CFD modelling can assist to ensure that the direction and flow rate of the air is effectively controlled by the fans over the complete car park to provide the most effective removal of fumes and smoke.

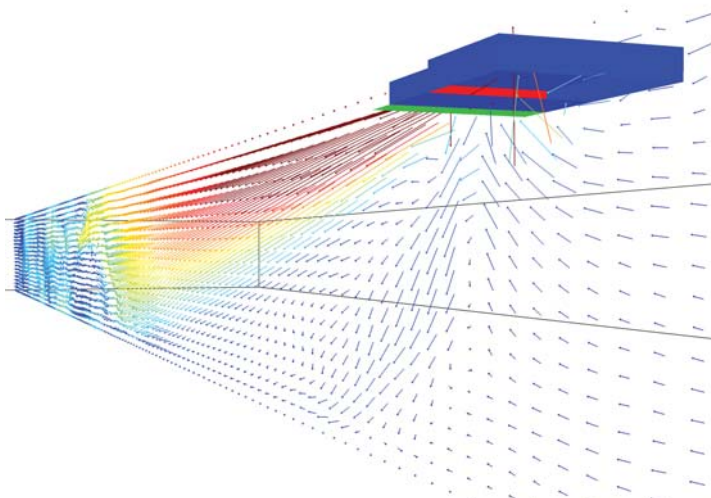

The image shows the velocity vectors produced by the CFD representation of a Colt Cyclone 100 fan unit

## TESTING UNDERTAKEN BY COLT

In 2004 Colt conducted the first UK full scale comparative tests between traditional methods of mechanical ventilation and impulse ventilation in Bristol.

These tests demonstrated that properly designed impulse systems can clear the smoke more quickly than ducted systems. For more information please see leaflet: PD 56 "Full Scale 'live' Smoke Tests".

A video is available to view at [www.coltinfo.co.uk](http://www.coltinfo.co.uk).



The Deputy Chief Fire Officer of Avon Fire & Rescue, Jerry O'Brien commented

*"The speed that the new products cleared the smoke compared to the old ducted system that we and maybe some others are using, is just remarkable. It is very impressive"*



VISIBILITY	SYSTEM		
	Traditional	Impulse	Induction
10 metres	At start	1 minute	1.5 minutes
20 metres	3.5 minutes	8 minutes	6 minutes
30 metres	13 minutes	13 minutes	9.5 minutes
40 metres	23 minutes	16 minutes	12.5 minutes
Rear wall details	27 minutes	18.5 minutes	16.5 minutes
Clear of smoke	41.5 minutes	32.5 minutes	28 minutes

The table shows the range of times taken in the demonstrations to achieve visibility distances and for the car park to become clear of smoke.



**Plan of test rig**

In 2005 Colt carried out large scale hot smoke testing with the Building Research Establishment (BRE) in Middlesbrough to prove both the concept of maintaining clear areas in a car park and to validate the CFD modelling approach used by Colt.

The aim of the tests was to demonstrate how an impulse ventilation system can be used to control the flow of smoke within a car park, keeping large areas effectively smoke free.

The results of the tests clearly indicated that impulse systems are capable of controlling the spread of smoke from a car fire and keeping significant areas of a car park effectively smoke free. BRE confirmed that the smoke movement during the fire with the impulse fans running was as predicted by the CFD modelling Colt had carried out before the tests. For more information please see leaflet PD 61“Impulse Ventilation for Smoke Control”. A video of the tests is available to view at [www.coltinfo.co.uk](http://www.coltinfo.co.uk).

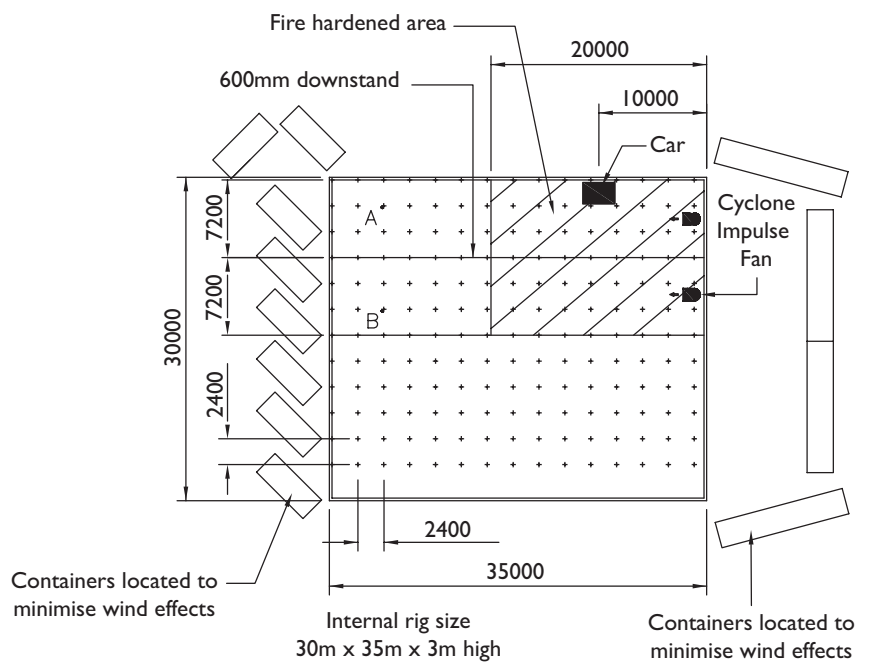

Average smoke temperatures (°C)			
Time period from ignition	Location	Measured	CFD
210-310s	A, 1m above floor	23.4	25.8
210-310s	A, 2m above floor	25.9	30.0
210-310s	B, 1m above floor	22.0	20.7
210-310s	B, 2m above floor	25.8	25.3
210-310s	C, 1m above floor	22.6	22.1
210-310s	C, 2m above floor	32.1	30.2
	Ambient	18.8-19.3	20.0

The table shows time averaged smoke temperatures as recorded during the demonstrations and predicted by the CFD analysis.

# Impulse Ventilation Systems

## CAR PARK FIRES

In the 12 year period 1994 to 2005:

- *There were 3,096 fires reported in car parks*
- *Of these 1,592 fires started in vehicles*
- *Most fires in car parks do not spread (to a car or another car), but fires which do spread to involve more than one car can result in significant structural damage*
- *About seven people are injured in car park fires each year.*

Source: BRE

## WHAT ARE IMPULSE VENTILATION SYSTEMS?

In recent years jet fan or impulse technology has established itself as the new standard in car park ventilation. Impulse ventilation systems are an alternative to ducted mechanical extract systems, overcoming many of the problems associated with such systems.

An impulse fan is similar to a tunnel jet fan, but has a reduced diameter in order to maximise headroom. It comprises an axial fan with inlet and exhaust attenuators and any necessary guards and flow distribution control devices.

A series of such free- blowing fans, mounted under the ceiling, induce air movement from the air inlet openings towards pre-designated extract points, moving smoke and fumes with it. The number and location of fans are carefully chosen to match the system design requirements, and in order to ensure that there are no dead spots for fumes and smoke to stagnate and collect.

## FEATURES AND BENEFITS OF IMPULSE SYSTEMS

**Easier and quicker installation** - Impulse fans are much quicker and easier to install than extensive ducting

**Lower excavation costs** - Low profile fans can be kept within downstand beams

**Lower maintenance** - No distribution ductwork to clean

**Optimal use of space** - Increased headroom or lower car park build height, with an increased number of parking bays

**Better car park security** - No ducting improves CCTV coverage, keeping the environment safer and lighter

**Sprinklers** - Impulse systems are eminently suitable for use with sprinkler systems. Where legislation requires sprinklers, it is possible for the approving authority to accept the deletion of sprinklers where an improved car park ventilation will be installed. In this instance, the impulse system will need to be able to maintain clear access conditions for fire-fighters.





**Becad Hospital, Middlesex**  
 By re-assessing the design, Colt was able to reduce a competitor's 35 impulse fans to 12 Cyclone induction fans.

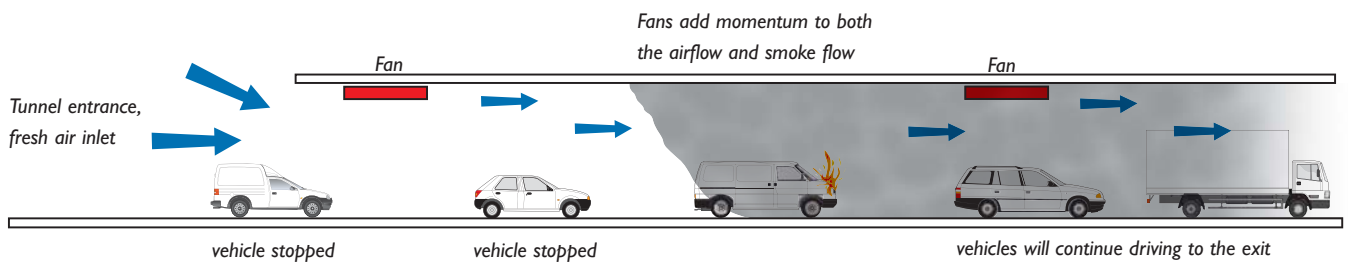

The principles of car park impulse ventilation have been developed from procedures used for tunnel ventilation. In the event of a fire, smoke will be 'pushed' and 'pulled' to the exit. Vehicles in front of the fire will continue through to the exit, whilst vehicles behind the fire will, of course, have to stop. Although trapped, these vehicles should be safe from the smoke.

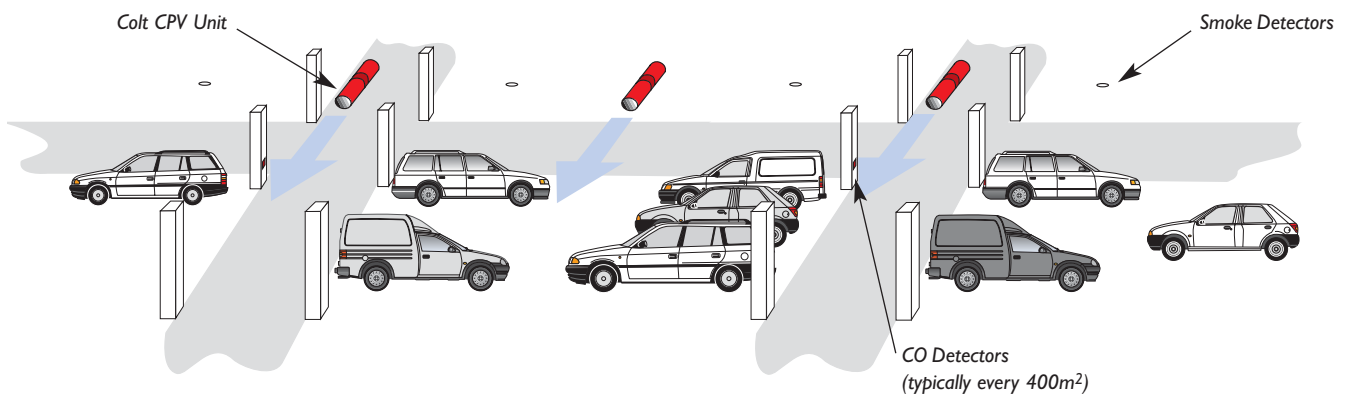

Fan positioning needs to take into account roof geometry (particularly deep downstand roof beams) and risk of airflow blockage by tall vehicles.

The introduction of CO detectors allows use of a more sophisticated control system to match the ventilation rate to the car park usage, further reducing running costs and noise levels.



## CASE HISTORY

### The Postbox, Birmingham

CLIENT: Cala Homes  
ARCHITECT: Ian Darby Partnership  
MAIN CONTRACTOR: Taylor Woodrow  
M&E CONTRACTOR: Rotary North West

The Postbox, Upper Marshall St, is a large mixed use development comprising apartments and office space in Central Birmingham spread over three blocks.

Colt provided smoke control systems for the apartment corridors and underground car park.

On each of the two levels of the car park, four Colt Cyclone induction fans move the air from the entrance ramp towards the extract system, which has also been supplied by Colt. The Colt extract system comprised attenuated high temperature axial fan units. Colt also provided a main control system as well as addressable carbon monoxide detectors. For day to day operation the system monitors the carbon monoxide levels within the car park and once a set point has been reached the system increases the ventilation rates.

Emergency control is fully automatic from the fire alarm detection systems or manually from the Fireman's Override Switches.

Colt was also contracted to provide the CFD report which confirmed the viability of the ventilation scheme.





# CASE HISTORY

**Arsenal**

ARCHITECT: HOK Sport  
MAIN CONTRACTOR: Sir Robert McAlpine  
SERVICES CONSULTANT: Buro Happold

A Colt impulse ventilation system has been installed at the new Emirates Stadium, constructed by Sir Robert McAlpine Ltd for Arsenal Football Club, in north London. Colt also supplied plant room louvres in a contract worth £1.2 million in total.

The Colt impulse system consists of 59 reversible Jetstream fans, four 1800mm extract fans, and all their associated carbon dioxide, smoke and heat detectors and controls. The fans are mounted under the ceiling around the car park, to move air and smoke towards each extraction point, avoiding the need for the extensive ductwork that would be required for a traditional system.

The benefits of the system include a more open environment, better CCTV coverage and lower initial and running costs. In the interests of maximum efficiency, with the reversible impulse fans linked to a wind direction sensor, the system can move the airflow around the car park in either a clockwise or anti-clockwise direction depending on the wind direction.

# Induction Ventilation Systems

## INDUCTION VENTILATION SYSTEMS

Induction ventilation is a further enhancement of the impulse ventilation concept.

Using the same principles as impulse ventilators, induction fans are yet slimmer, more efficient and powerful, thus reducing the number of units required. A typical induction fan has a throw of approximately 40 m as opposed to 20 m for an impulse fan. The floor area ventilated per fan is significantly greater, equating to a requirement for fewer units.

Slimmer units can allow a reduced excavation cost and lower car park height. Ducted systems are often deeper in places and need to be run under any downstand beams whereas fans can be located between them. This demonstrates the potential savings both in excavation and in build height for the developer and contractor.

*In a recent project in the centre of London, Cyclone fans were specified since they saved significant dig-out costs. The contractor would have needed to spend an additional £248,000 excavating an additional 150mm of earth in order to accommodate the greater unit depths of an alternative system*

Fewer units mean lower cabling and controls requirements and lower installation and maintenance costs.

In addition, the units can be inverter controlled for a further reduction in power consumed.

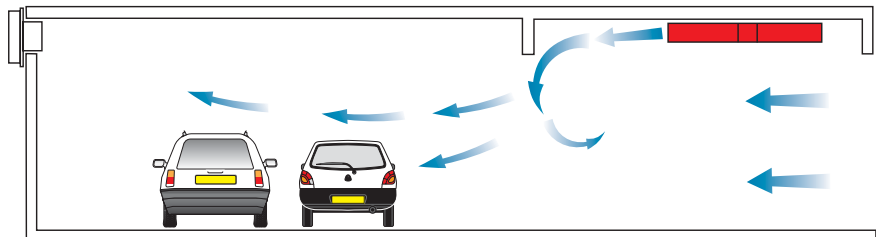

*Air turbulence created by the downstands when using a typical impulse fan*

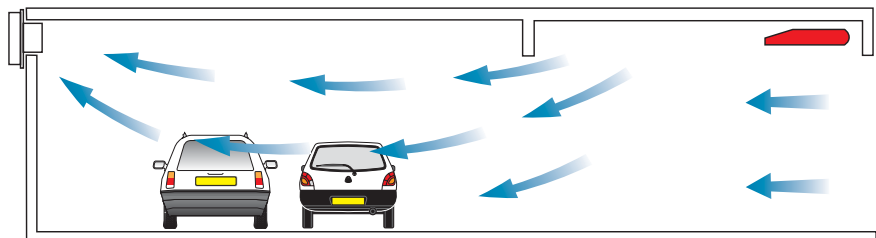

*Air turbulence is dramatically reduced when using a Colt Cyclone CPV fan*



# CASE HISTORY

## Paradise Street

ARCHITECT: Building Design Partnership  
MAIN CONTRACTOR: Laing O'Rourke/Crown House  
SERVICES CONSULTANT: WSP  
FIRE CONSULTANT: Tenos

In 2006 Colt won the contract for what was believed to be the UK's first smoke control system for a car park. It has been designed specifically to enable occupants to escape from a car park and to assist fire-fighting crews, rather than simply as a smoke clearance system that is commonly applied to car parks.

The £2.5 million project - part of Liverpool's £920 million Paradise Street retail, leisure and residential development - involved the supply and installation of a Colt impulse car park ventilation system for the massive 66,000m<sup>2</sup>, 2,000-space car park that was built beneath Chavasse Park in Liverpool.

The four-storey underground car park was fitted with 80 Cyclone induction fans and 22 Jetstream impulse fans. These were designed to keep smoke completely away from the escape routes without the need for smoke curtains or physical barriers.

John Perry, senior consultant at Colt, explained: "Nearly all of the car parks we have done in the UK so far are smoke clearance systems, not smoke control systems. With the former, you have a designated extract rate.

This car park is different because it is so large (with the largest level being 232m by 95m) that we have to move smoke from a fire in defined corridors.

So, this is a fully designed scheme rather than a simple air change rate scheme. We are not merely clearing the smoke - we are controlling it."

Prior to the award of the contract, engineers from Colt and the Building Research Establishment demonstrated the effectiveness of the Colt impulse scheme for the Paradise Street project by conducting a series of hot smoke tests in a simulated car park in Middlesbrough. These established the accuracy of CFD modelling Colt had made before the test, and predicted that the scheme of impulse fans would be capable of controlling the spread of smoke from a car fire and keeping significant areas of the car park smoke free.

Smoke control for means-of-escape is described on page 4. See page 17 for a schematic diagram of this project.

# Extract Systems

## EXTRACT SYSTEMS

There needs to be an adequately designed ventilation system to extract the air. In addition, where the natural air supply is insufficient, supply fans may also be required.

Depending on the scope required, Colt is able to provide a wide variety of mechanical extract fan and motor assemblies to suit the required duty and temperature rating. These include long case, short case and plate mounted axial fans.

Where required for smoke extraction, Colt extract fans have been tested to the exacting standards of EN 12101-3: 2002.

CIBSE Guide Volume A: 1999, Environmental Design, sets out a recommended maximum noise level of NR55 in car parks. Colt car park systems can be designed to achieve these noise levels if required.

Colt is able to mix and match components to suit the requirements of almost any mechanical extract system.

## OTHER ANCILLARIES

Colt also provide:

- Ductwork, including attenuators, grilles, volume control dampers, shut-off dampers, bends and transitions.
- Weathered external terminations, including louvres, dampers, turrets, gravity shutters, cowls and motorised ventilators such as the Seefire, ACE, Firelight and Meteor.



Extract plant at the Observatory Apartments, Walsall



**B5 Southside, Birmingham**  
2 Inlet Fans, 13 Cyclones, 2 Extract  
Fans, Dampers and Grilles, CO &  
Smoke Detectors



Louvre terminations at the  
Observatory Apartments, Walsall



Extract fans at The Foundation, Liverpool



Extract plant at Gunwharf Quays, Portsmouth

# Controls

## CONTROLS

The design of the controls including sensors is an integral part of any car park ventilation system. The arrangement of sensors is determined at the design stage, along with the controls cause and effect, which determines the way in which the equipment responds to any given conditions.

### Day to day condition

The simplest (but rarely used) option is to run the system at a constant speed, providing a ventilation rate of 6 ACH throughout the car park. To reduce energy costs a CO detection system is used to allow the system to run at a reduced ventilation rate in periods when vehicle movements are low.

Using a single output detector, two stage control can be provided, typically switching at 15-20ppm of CO. Using variable output detectors, the system can provide additional stages or modulate to match the ventilation rate to the car park usage. The effect of this is that the flow rates can be reduced to practically zero at times when there are no vehicle movements in the car park.

### Fire condition

For a smoke clearance system, detection is required to indicate which level of the car park contains the fire, if the car park has more than one level. Upon detection all fans on that level operate at high speed, all other fans are switched off and the extract fans are switched to full speed, extracting only from the fire level.

For a smoke control system, addressable detection is required to pinpoint the fire location to allow correct selection of fan operation to maintain the required clear areas.

Colt can provide carbon monoxide detectors, nitrogen dioxide (NOx) sensors and heat/smoke sensors as well as fire alarm inputs along with all their necessary controls and battery back up facilities, linked into an addressable fire detection system.

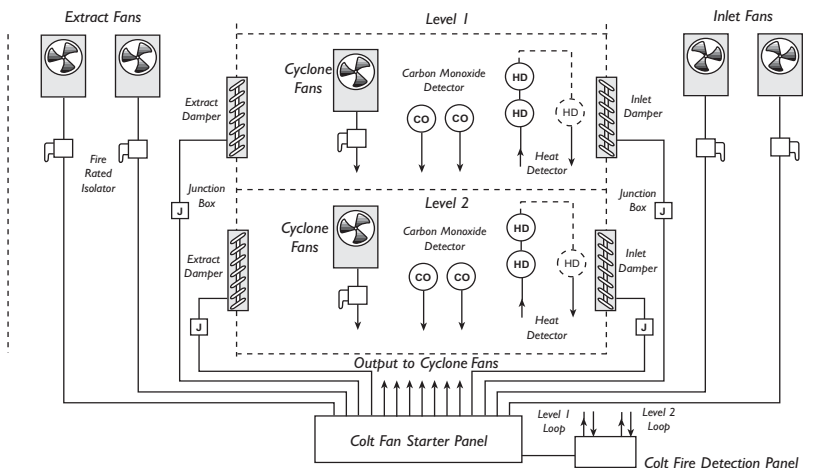

The Postbox Birmingham



A typical CO detector

### TYPICAL CONTROL SCHEMATIC

Shown left is a typical control system for a two level car park with CO control, mechanical exhaust and mechanical inlet





Gunwharf Quays, Portsmouth



Control panel manufactured by Colt undergoing final inspection

TYPICAL SYSTEM DESIGN SCHEMATIC

**Paradise Street Car Park Level B1**

Please turn to page I3 for a brief description of this project

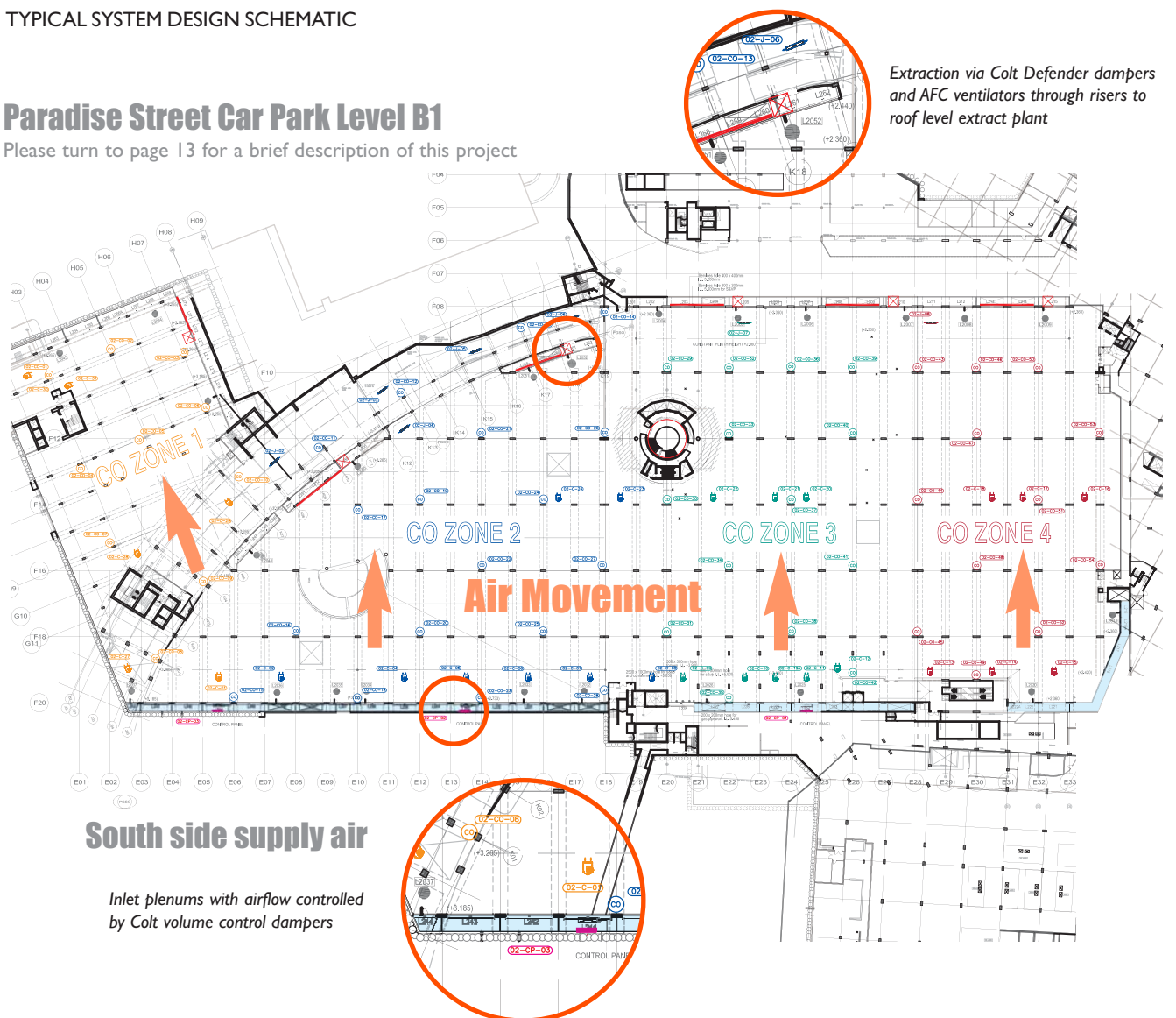

### THE COLT PACKAGE

Colt can offer the complete package, which could include:

- Scheme design. CFD analysis and report
- Supply of impulse fans, extract and/or inlet fans, ductwork and dampers, control systems including CO and heat/smoke detectors
- Installation and wiring
- Commissioning
- Service and maintenance.

A free full system check will be carried out approximately 9 months after a Smoke Control System has been installed and commissioned by Colt. Besides the opportunity to check that the system is performing as designed, this will allow for any further training of local personnel that may be necessary. Assuming that this visit falls within the warranty period, any defective parts would be replaced free of charge. A test certificate will be issued.

### OTHER REASONS TO CHOOSE COLT:

Colt Smoke Control systems are **suited to both commercial and industrial buildings**, and may be adapted to suit most architectural requirements.

Over the years **Colt has funded a large proportion of the research** into smoke control, and its representatives maintain an **unparalleled level of technical expertise**.

Colt's **CFD modelling approach is reliable** and has been confirmed by empirical full scale hot smoke tests.

Colt's **in-house research and development capability** ensures that Colt fire protection systems are designed, tested and updated by Colt to meet or exceed relevant legislation and standards.

The majority of Colt's Smoke Control systems are **manufactured in the UK** under BS EN ISO 9001:2000 and BS EN ISO 14001:2004.

### COLT SERVICE

Part of the Colt Group of companies, Colt Service offers a comprehensive range of maintenance packages incorporating the maintenance and repair of all building services equipment including non Colt products.

Colt Service provides a 24 hour, 365 day emergency cover as standard.

### MAINTENANCE

Maintenance of a smoke control system is essential. Regular maintenance protects your investment and brings peace of mind that the system will operate effectively in an emergency.

British Standard BS 5588-12 recommends that smoke control systems should be serviced at least once a year and tested weekly.



"People feel better in Colt conditions"



Architectural Solutions  
 Climate Control  
 Smoke Control  
 Service and Maintenance

**Colt International Limited**  
 New Lane Havant  
 Hampshire PO9 2LY  
 Tel +44(0)23 9245 1111  
 Fax +44(0)23 9245 4220  
 info@coltgroup.com  
 www.coltinfo.co.uk